

K-ARRAY
Unique Audio Solutions

Pinnacle mark II
SYSTEMS CONFIGURATIONS

THE POWER OF ONE

INNOVATIVE, PURE, EVEN SOUND

A professional, versatile, audio diffusion system capable of blending in but standing out with exceptional high performance and

innovative even coverage built as one easy to use solution for multiple applications.

“FITSPERFECTLY”ISANUNDERSTATEMENT

This is an audio system shaped for performance, capable of adapting to any space and hiding from sight. Pinnacle is the key to providing the most prestigious theaters in the world thanks to its extreme discretion which manifests itself both from an aesthetic/visual point of view and in terms of sound quality which is never artificial or altered.

The Pinnacle series does not let the speaker spoil the moment from small events to large theatres thanks to a simple modular configuration that blends into background with ease.

The more elements you have, the wider the choice of configurations you can create: by aggregating a large number of units in a more complex large system, medium-large events can be simple.

The Pinnacle-[KR102](#), [KR202](#) and [KR204](#) Mark II are made up of Kobra columns with 2-inch transducers, the Pinnacle-[KR402](#) and [KR404](#) Mark II are the result of more combinations of 3.15-inch Python and finally the Pinnacles-[KR802](#) and [KR804](#) Mark II consist of Kayman columns with 4-inch transducers. All three models are made up of [Thunder](#) subwoofers, in their different variants ([KS1](#) / [KS1P](#), [KS2](#) / [KS2P](#), [KS3](#) / [KS3P](#), [KS4](#) / [KS4P](#)).



LEAVE YOUR BIG SYSTEMS AT HOME

Pinnacle's design isn't simply our interpretation of what a pro audio system can be but what it should be thanks to K-array's unique "Pure Array Technology" (PAT) - [watch the webinar](#) -, which is the maximum homogeneity of diffusion that can reach

everyone in the room without compromising the sound quality for the listener from the front of the event all the way to the back, without using a lot of logistical and rigging efforts.

CALM AND COMPOSED, COME RAIN OR SHINE

Built For Heavy Touring On The Road

With a particular focus on audio technicians and rentals, the amplifier of the Pinnacle features a PowerCon True connector for powering the mains, allowing easier wiring extension and greater resistance to bad weather.

To add that extra bit of safety, the entire connector panel is housed in a new area completely recessed inside the sub chassis, making it a practical self-shelter solution, already sufficient for lighter heavy rains.



ARE YOU A RENTAL?

The more elements you have, the wider the choice of configurations you can create: by aggregating a vast number of units in a complex medium to large system; This is possible by breaking down a large system into many individual parts, one complements

the other simultaneously making it also easy to manage smaller events. In addition to the number of diffusers, each system can be composed of three different types of column elements revealing the incredible scalability of Pinnacle.



EXTREME DISCRETION

Surely among the most compact high-performance systems ever produced, with its elegant and discreet shapes, Pinnacle is the key to access the most prestigious theaters in the world thanks to its extreme discretion which manifests itself both from an aesthetic / visual point of view and in terms of sound quality which is never artificial or altered. Pinnacle represents more than any other K-array product, the pure essence of professional audio, which does not need to be seen.

Camouflaged between the intricate architecture of a prestigious theater such as the moldings of the

proscenium of a prestigious theater such as the Teatro alla Scala (Milan) or the Royal Opera House (London), the powerful sound reproduced by Pinnacle is extremely natural thanks to Pure Array Technology (PAT), and reaches the spectator in a harmonious way, as a creative extension of the performers on stage.

The theater is just one of many applications where Pinnacle can improve the sound field for a better experience.



INPUT TERMINALS SELECTION AND LINK WIRING

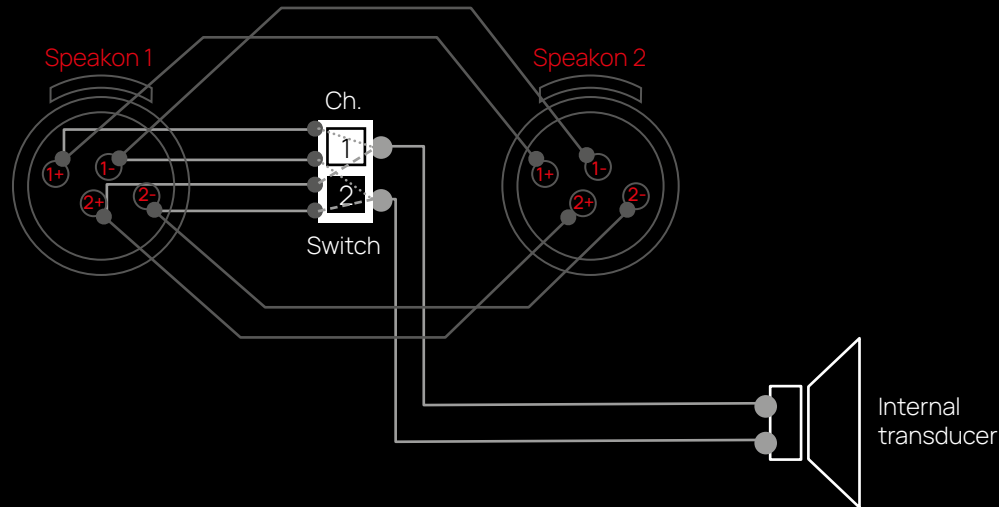

ACTIVE SUBWOOFER

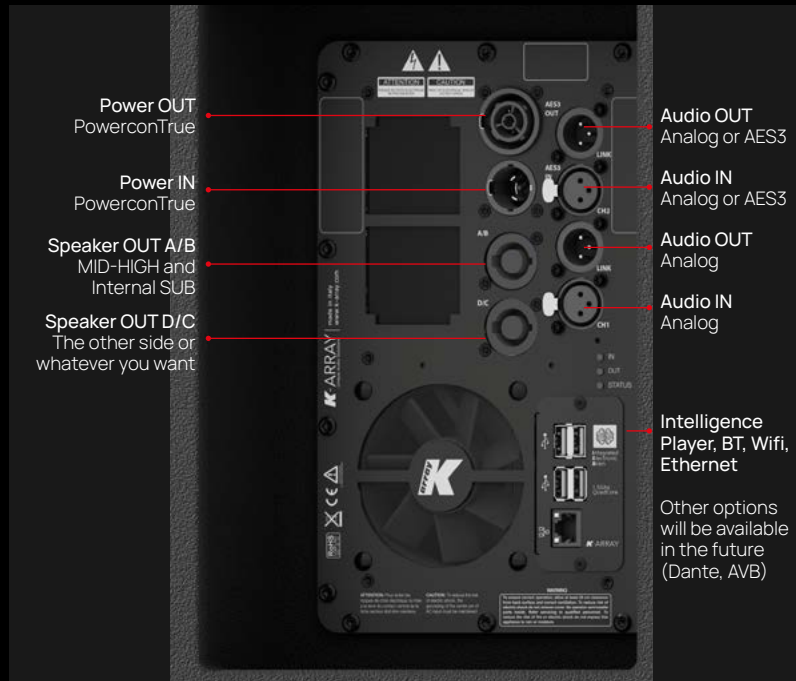

PASSIVE SUBWOOFER

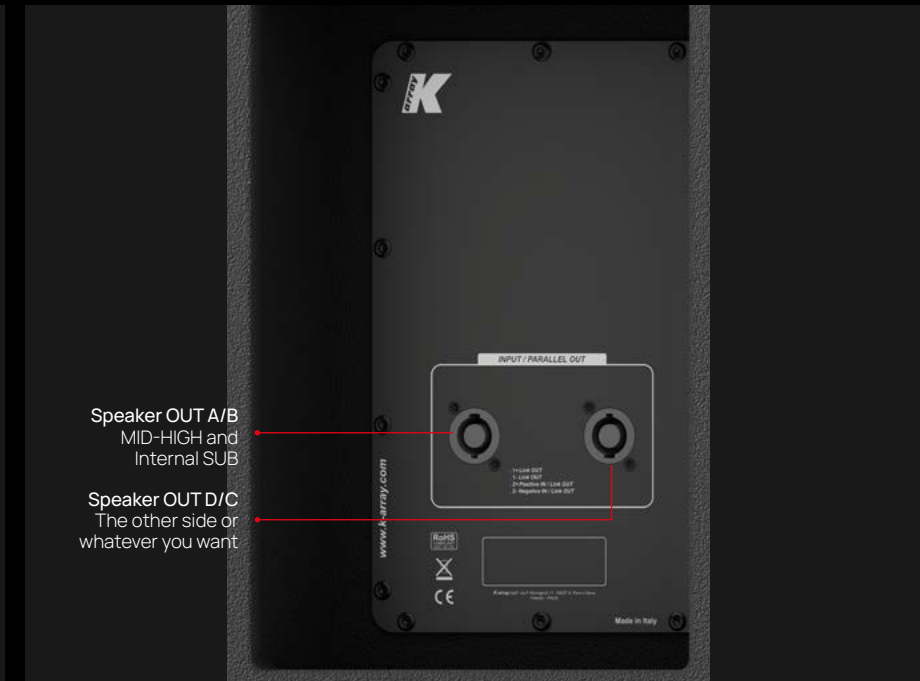



K-ARRAY
Unique Audio Solutions

FULL POWER, NO COMPROMISE

A harmonious ambience created by Pinnacle's intelligent internal configuration

Built with powerful class D amplifiers fully managed by sophisticated integrated DSP processors, the electronics allow the combination of Pinnacle to deliver not only the power signal to the subwoofer itself, but offers up to three additional channels of amplification and processing, thus becoming a complete control unit that allows you to drive an entire stereo system using only one active unit.





K-frameworks3
Mac or PC



Mobile APP
Web APP

STAY IN COMPLETE CONTROL

A Perfect Blend of Technology To Extend The Possibilities

A new generation of audio intelligence (osKar) allows you to manage the entire ecosystem through various control platforms and offers features directly on board the device, in order to simplify its use, and extend the possibilities. The osKar operating system offers the possibility to control the main functions of the DSP to manage Volumes, Routing and Presets directly from the device itself, it also has a USB player and a web stream receiver.

The remote control of subwoofers can take place through three different types of software released, starting from the most complete K-framework for Windows and Mac, passing from a more intuitive web app and arriving at the more simplified mobile app (wi-fi). There are also APIs and plugins to control these devices via third-party controllers. An LED located on the front of each machine allows the user to understand which device he has entered into communication with.



Integrated
Electronic
Brain

POWERED BY INTELLIGENCE

Enhanced performance and easy tuning are now managed by the Integrated Electronic Brain - IEB - implemented into K-array amplifiers. More than a traditional DSP, the built-in micro electronics driven by the integrated operating system osKar features expansive sound processing, offering complete user control over the system performance

osKar

Operative System

Volumes, Signal Routing, Presets as well as a complete USB player, are directly manageable through three different types of software and dedicated professional interface.

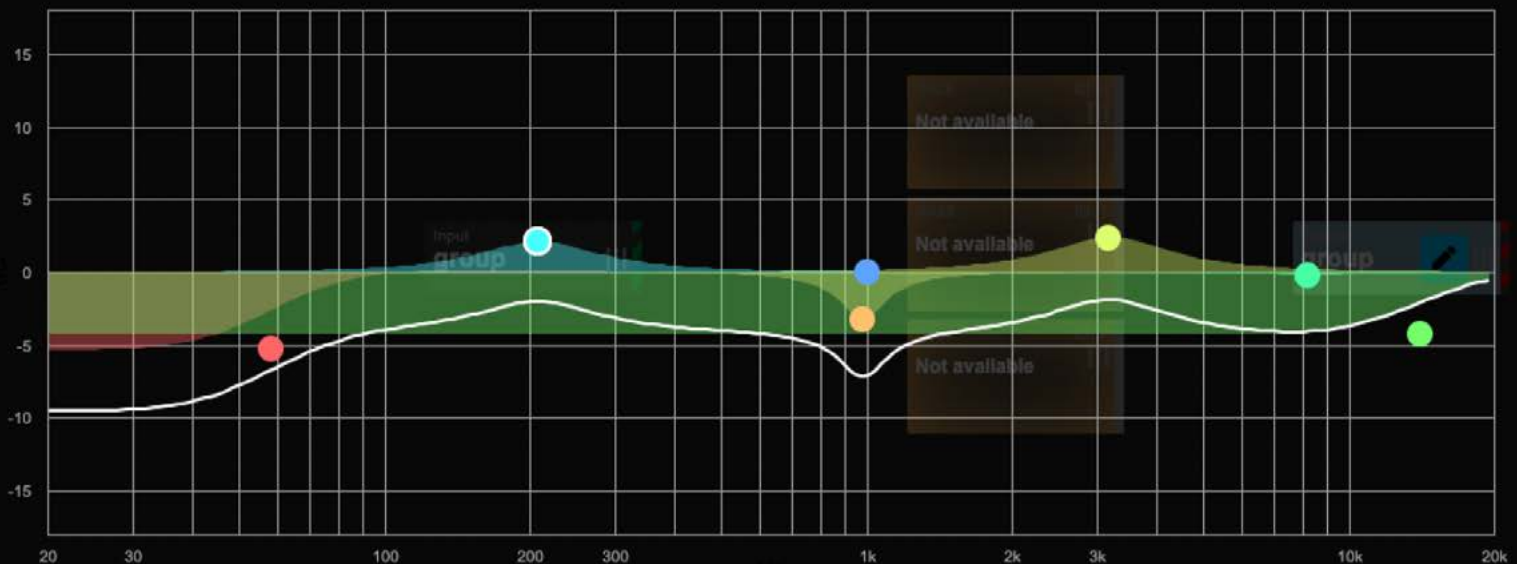

STUNNING TO LOOK AT, PLEASING TO THE EAR, CHOSEN FOR RELIABILITY.

*“One of the most compact systems ever produced,
with its elegant and discreet design.”*

Alex Tatini - CEO

The material used for the construction of the K-array speakers is certainly a distinctive element that makes the K-array products unique, contributing both to the reduction of dimensions and to durability even in unfavorable weather conditions. Line array elements such as Kobra, Python and Kayman are in fact built with a partly handcrafted process of stainless steel sheet, skilfully cut, folded and welded with the utmost care. There is a long research project behind it, to minimize vibrations and unwanted resonances of the material.

For the Kobra, Python and Kayman versions, the metal also has the possibility of being subjected to galvanic treatments for a more luxurious finishes such as 24k gold plating, or a processing of the raw material such as brushing or polishing. mirror that makes the product look camouflaged on the surface where it is located. The polishing in fact allows the product to be discreet, thanks to the play of reflection, of the same texture of which the background is composed.



**CRAFTED
TO LAST**

A SERIOUS TIME SAVER

DESIGNED FOR EFFORTLESS,
FAST MOUNTING

For the technicians who need more time, the Pinnacle introduces a new self-centering system for incredible stability to mount up

to 8 Pinnacle units with just 1 person in a few minutes.

Pinnacle gives you more time to set up and tune thanks to its effortless mount and dismount system that is lightweight, compact and made easy to control.

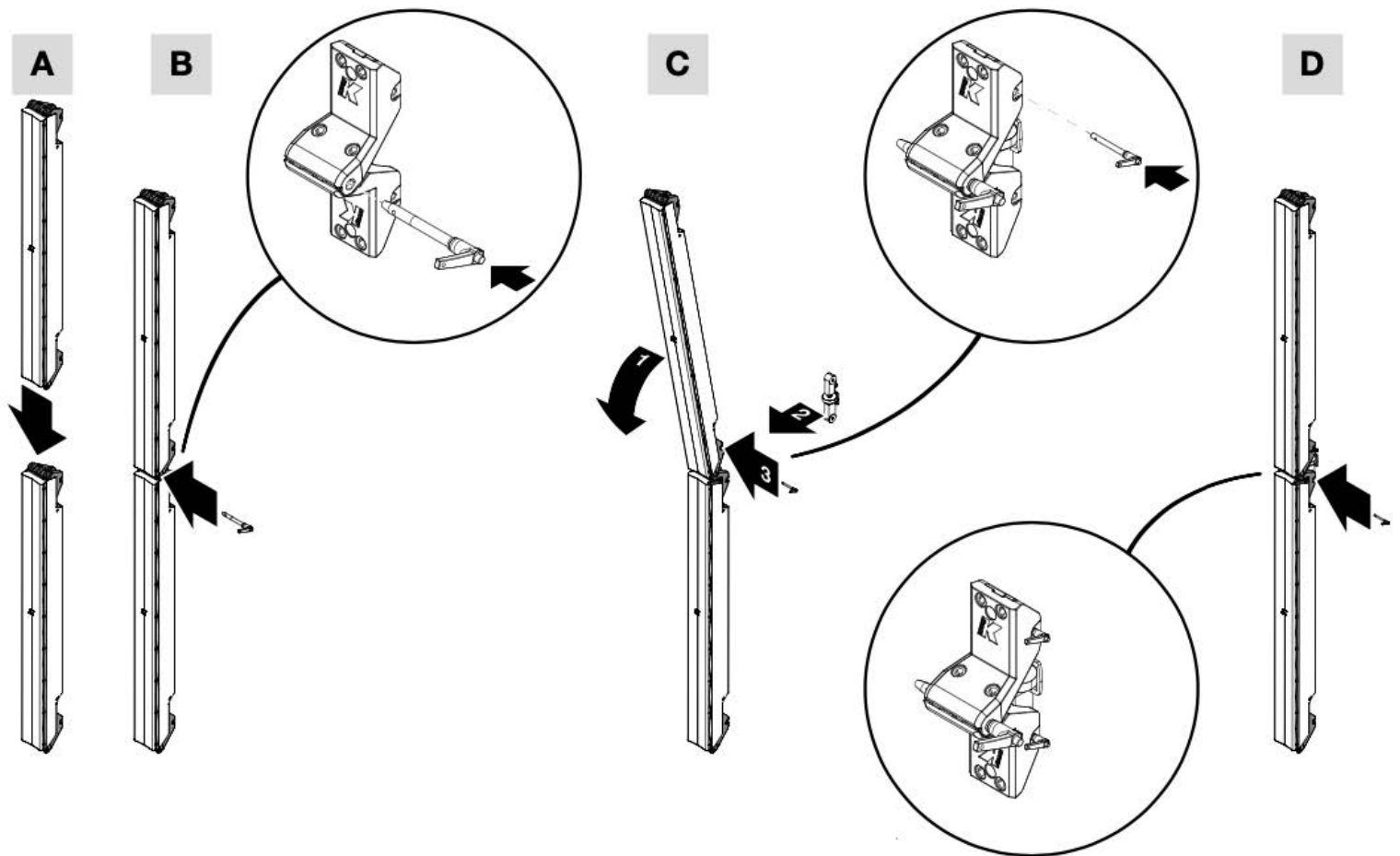

New **K-JOINT3**

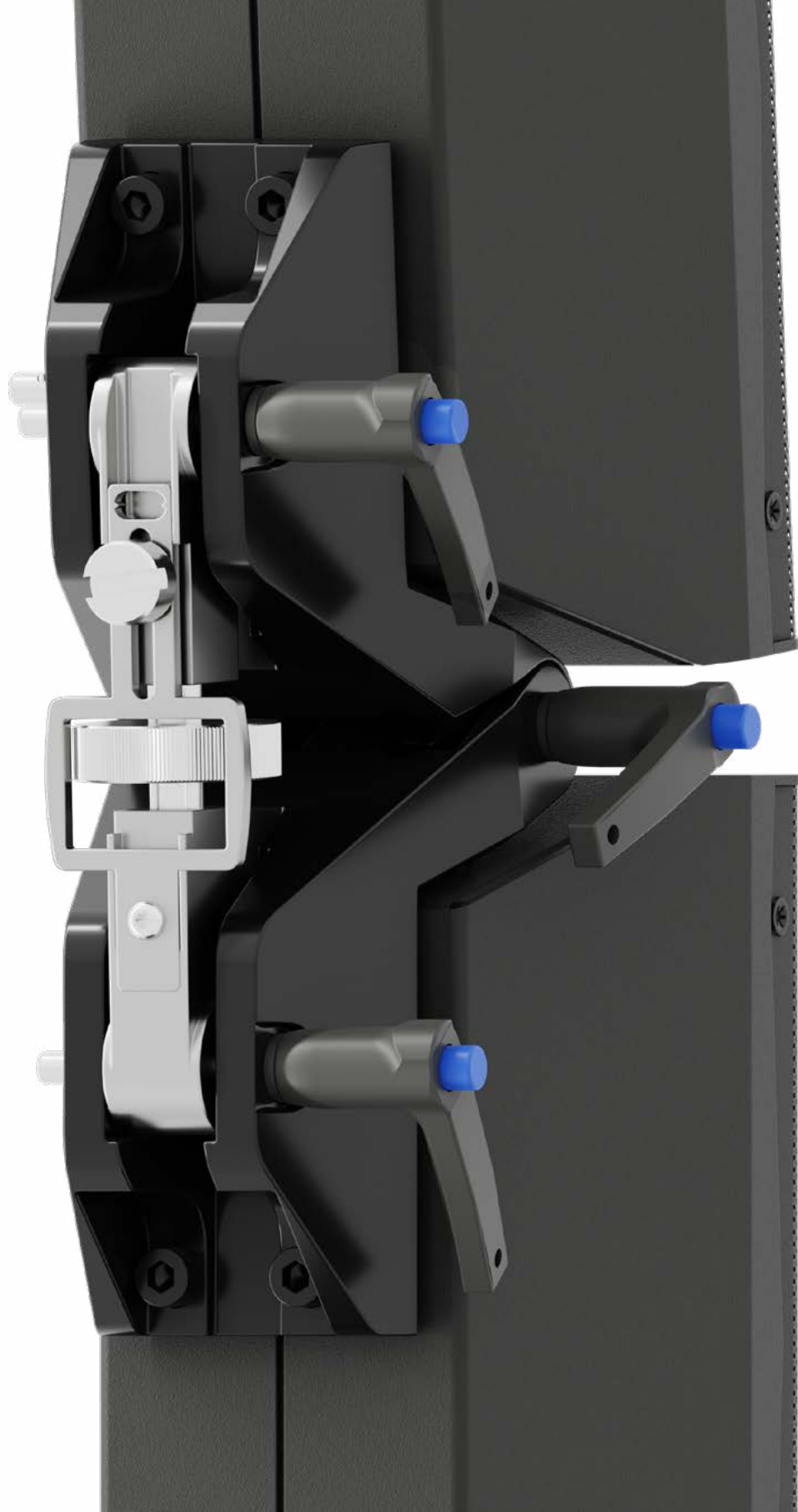

Pinnacle mark II





Pinnacle mark II

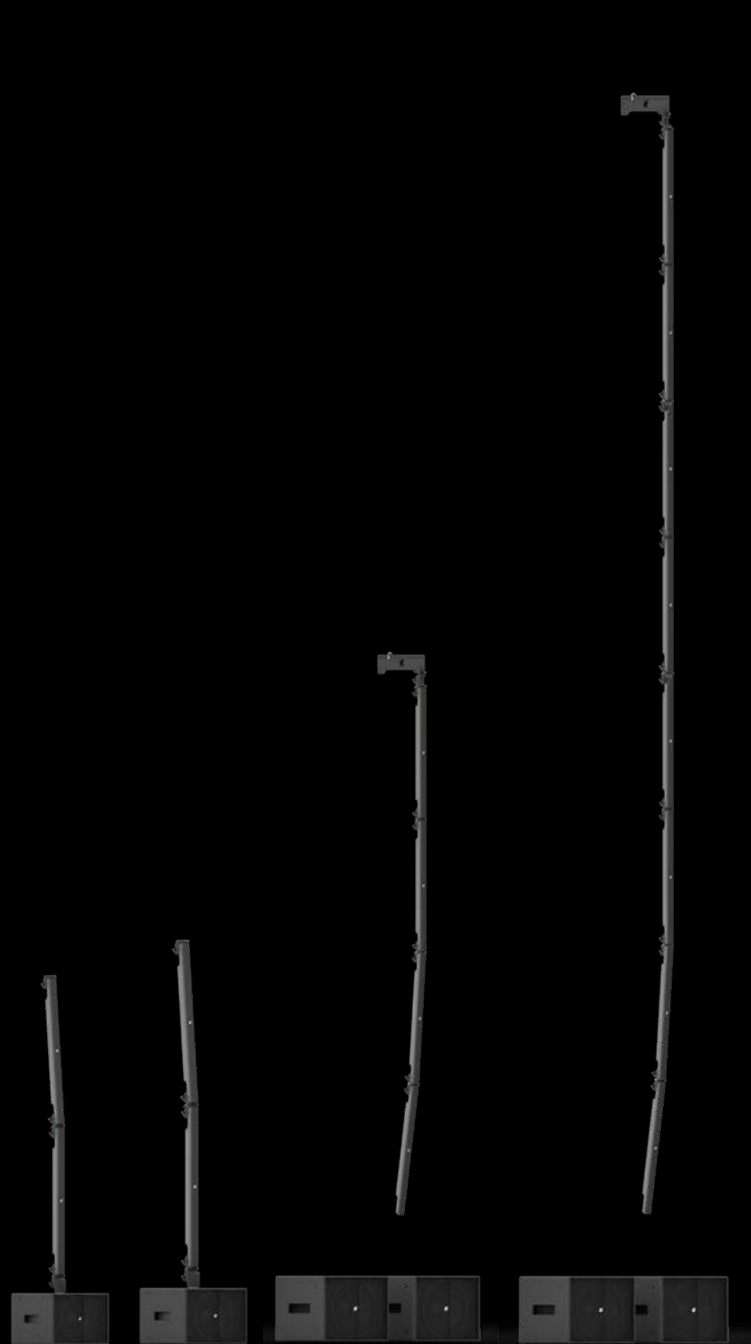

Pinnacle-KR2

pag. 21



Pinnacle-KR3

pag. 26



Pinnacle-KR4

pag. 30

Pinnacle mark II

SYSTEMS
CONFIGURATIONS

Pinnacle-KR2

Pinnacle-KR102 II pag. 22

Pinnacle-KR202 II pag. 23

Pinnacle-KR204 II pag. 24



Kobra-KK102 I
16 x 2" neodymium
magnet woofers



Thunder-KS1
12" neodymium
magnet woofers



Thunder-KS2
18" neodymium
magnet woofers

Pinnacle-KR2

K-ARRAY
Unique Audio Solutions

Pinnacle-KR102 II

- 2x **Kobra-KK102 I**
- 1x **Thunder-KS1 I**
- 1x **Thunder-KS1P I**
- 2x **K-KKPOLE**
- 2x **K-JOINT3**
- 2x **K-FOOT3**

Color Available

- White
- Black

Accessories Included



4x **K-JOINT3**



2x **K-FOOT3**



2x **K-KKPOLE**

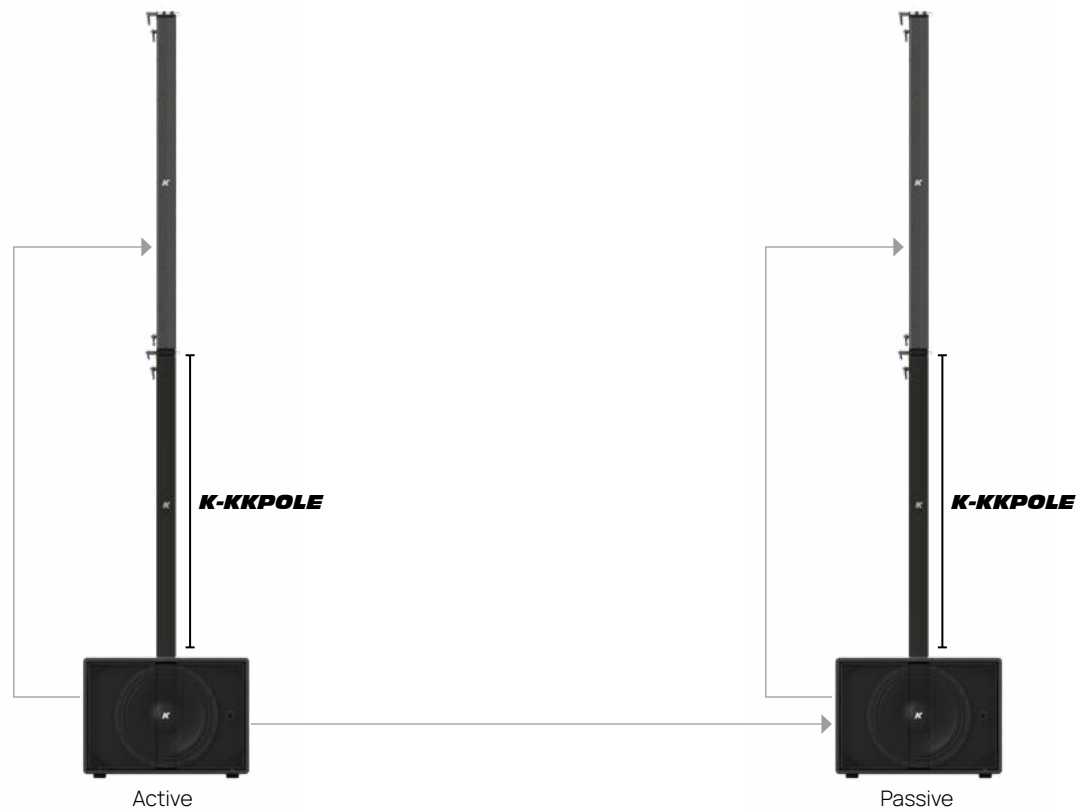

CONFIGURATION 1

Pinnacle-KR2

Pinnacle-KR202 II

- 4 x **Kobra-KK102 I**
- 1 x **Thunder-KS2 I**
- 1 x **Thunder-KS2P I**
- 4 x **K-JOINT3**
- 2 x **K-FOOT3**

Color Available

- White
- Black

Accessories Included



4 x **K-JOINT3**



2 x **K-FOOT3**

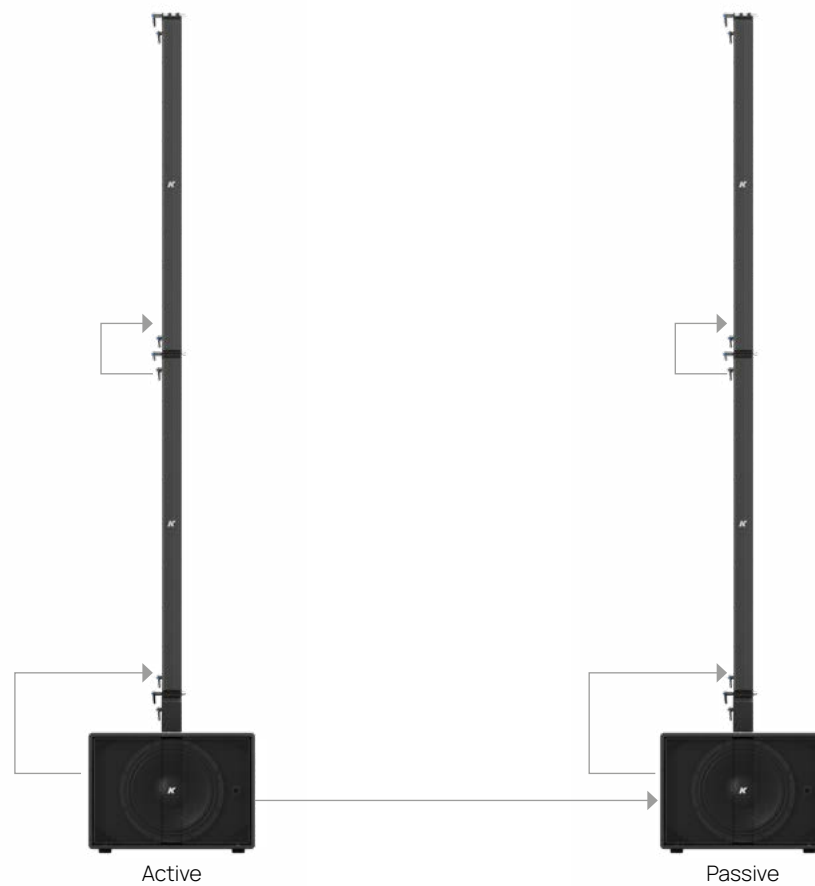

CONFIGURATION 1

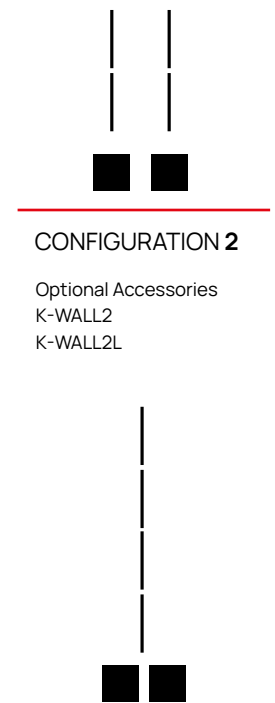

CONFIGURATION 2

Optional Accessories
K-WALL2
K-WALL2L

CONFIGURATION 3

Pinnacle-KR2

K-ARRAY
Unique Audio Solutions

Pinnacle-KR204 II

- 8 x **Kobra-KK102 I**
- 2 x **Thunder-KS2 I**
- 2 x **Thunder-KS2P I**
- 2 x **Flybar**
- 8 x **K-JOINT3**
- 4 x **K-FOOT3**

Color Available

- White
- Black

Accessories Included



8 x **K-JOINT3**



4 x **K-FOOT3**



2 x **FLYBAR**

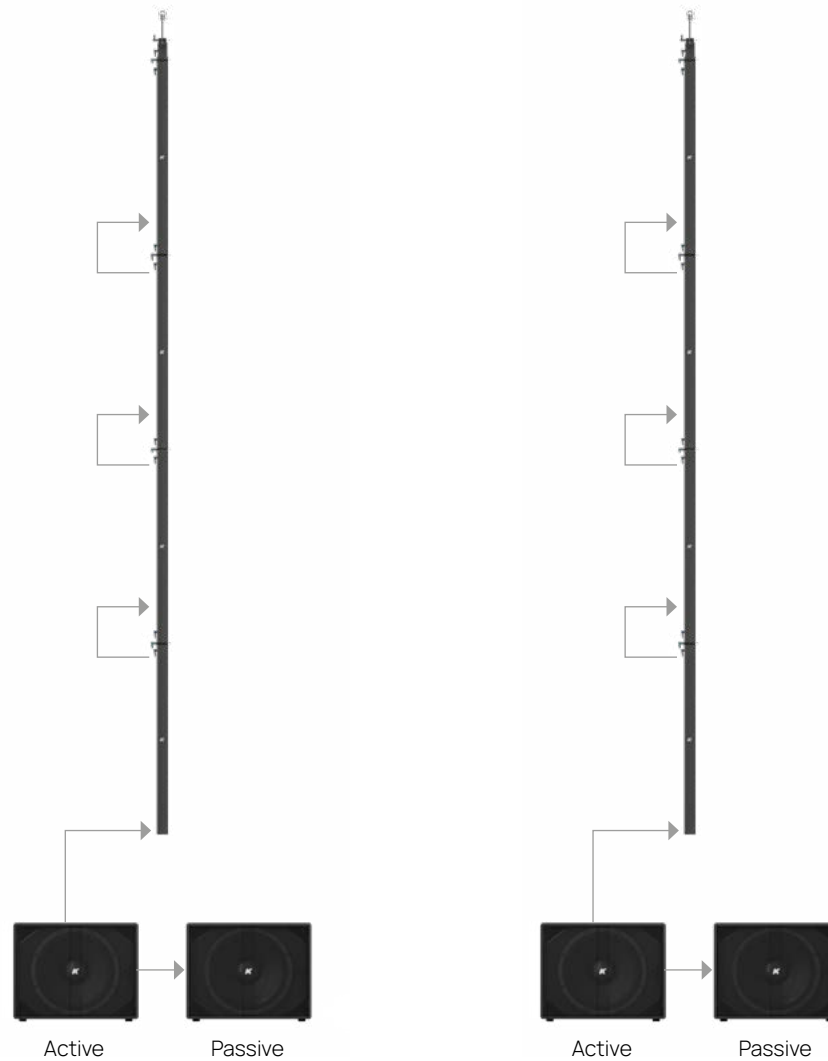

CONFIGURATION 1

CONFIGURATION 2

Optional Accessories
K-WALL2
K-WALL2L

CONFIGURATION 3

Pinnacle-KR2

2 x **Pinnacle-KR204 II**

16 x **Kobra-KK102 I**
4 x **Thunder-KS2 I**
4 x **Thunder-KS2P I**
2 x **Flybar**
16 x **K-JOINT3**
4 x **K-FOOT3**

Color Available



Accessories Included



16 x **K-JOINT3**



4 x **K-FOOT3**



2 x **FLYBAR**

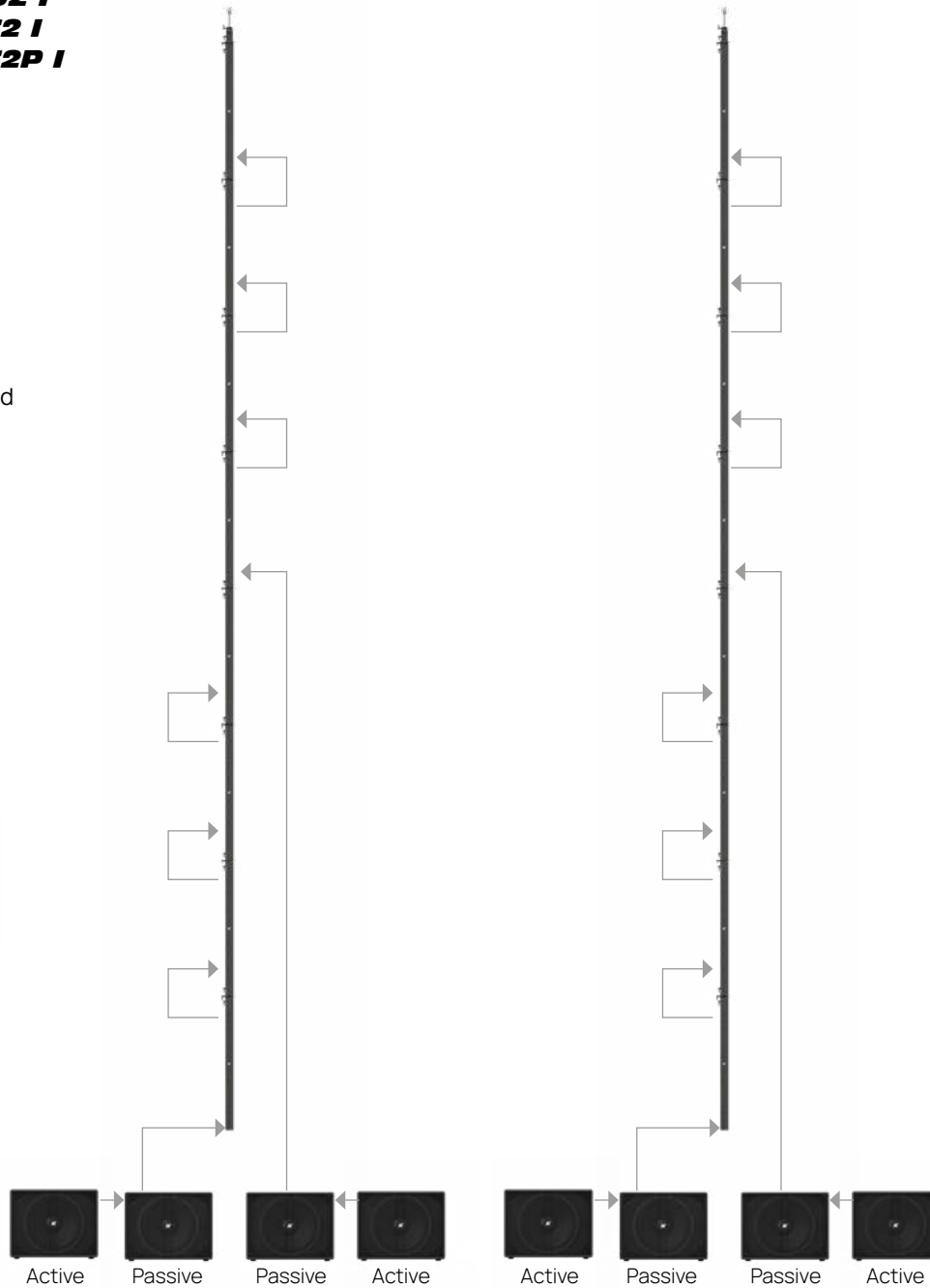

CONFIGURATION 1

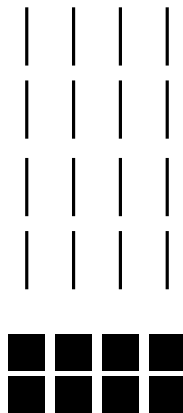

CONFIGURATION 2

Optional Accessories
K-WALL2
K-WALL2L

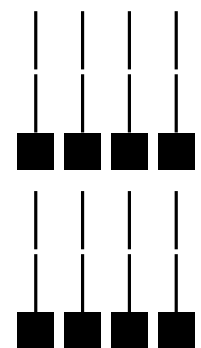

CONFIGURATION 3

Pinnacle mark II

Pinnacle-KR3

Pinnacle-KR402 II pag. 27

Pinnacle-KR404 II pag. 28



Python-KP102 I
12 x 3,5" neodymium
magnet woofers



Thunder-KS3
21" neodymium
magnet woofers

Pinnacle-KR3

Pinnacle-KR402 II

- 4 x **Python-KP102 I**
- 1 x **Thunder-KS3 I**
- 1 x **Thunder-KS3P I**
- 4 x **K-JOINT3**
- 2 x **K-FOOT3**

Color Available

- White
- Black

Accessories Included



4 x **K-JOINT3**



2 x **K-FOOT3**



CONFIGURATION 1

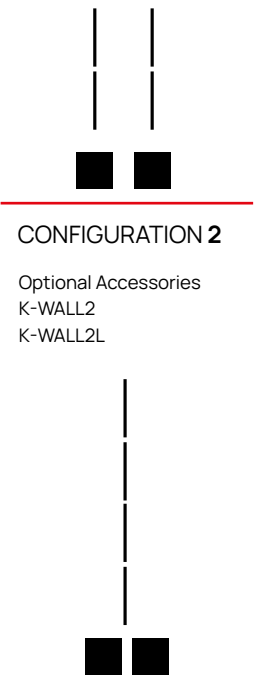

CONFIGURATION 3

Pinnacle-KR3

K-ARRAY
Unique Audio Solutions

Pinnacle-KR404 II

- 8 x **Python-KP102 I**
- 2 x **Thunder-KS3 I**
- 2 x **Thunder-KS3P I**
- 2 x **Flybar**
- 8 x **K-JOINT3**
- 4 x **K-FOOT3**

Color Available

- White
- Black

Accessories Included



8 x **K-JOINT3**



4 x **K-FOOT3**



2 x **FLYBAR**

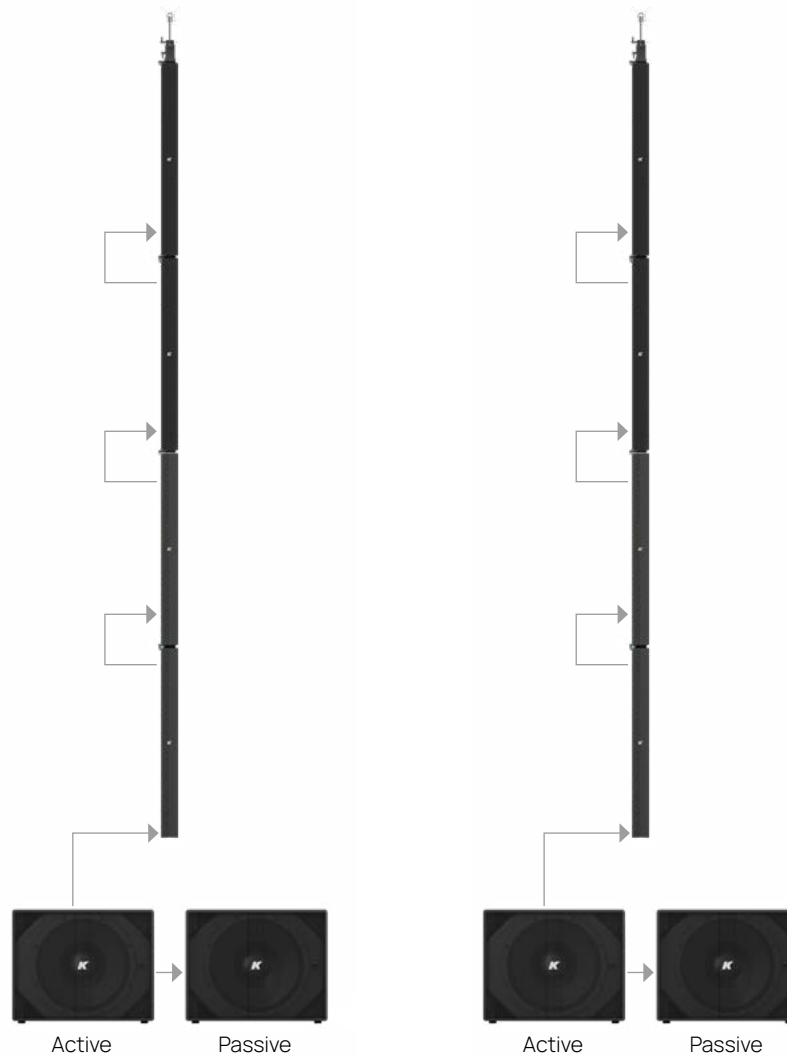

CONFIGURATION 1

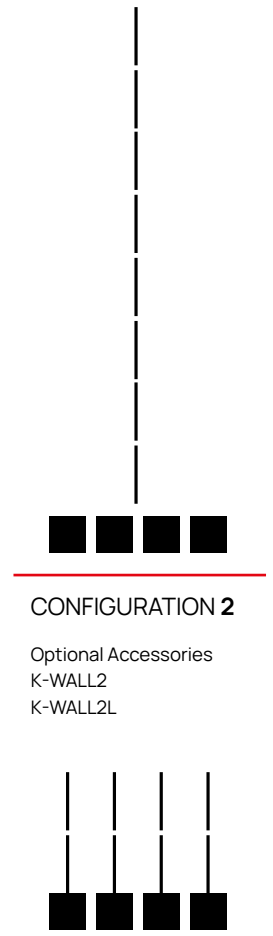

CONFIGURATION 2

Optional Accessories
K-WALL2
K-WALL2L

CONFIGURATION 3

Pinnacle-KR3

2 x **Pinnacle-KR404 II**

16 x **Python-KP102 I**

4 x **Thunder-KS3 I**

4 x **Thunder-KS3P I**

2 x **Flybar**

16 x **K-JOINT3**

4 x **K-FOOT3**

Color Available



Accessories Included



16 x **K-JOINT3**



4 x **K-FOOT3**



2 x **FLYBAR**

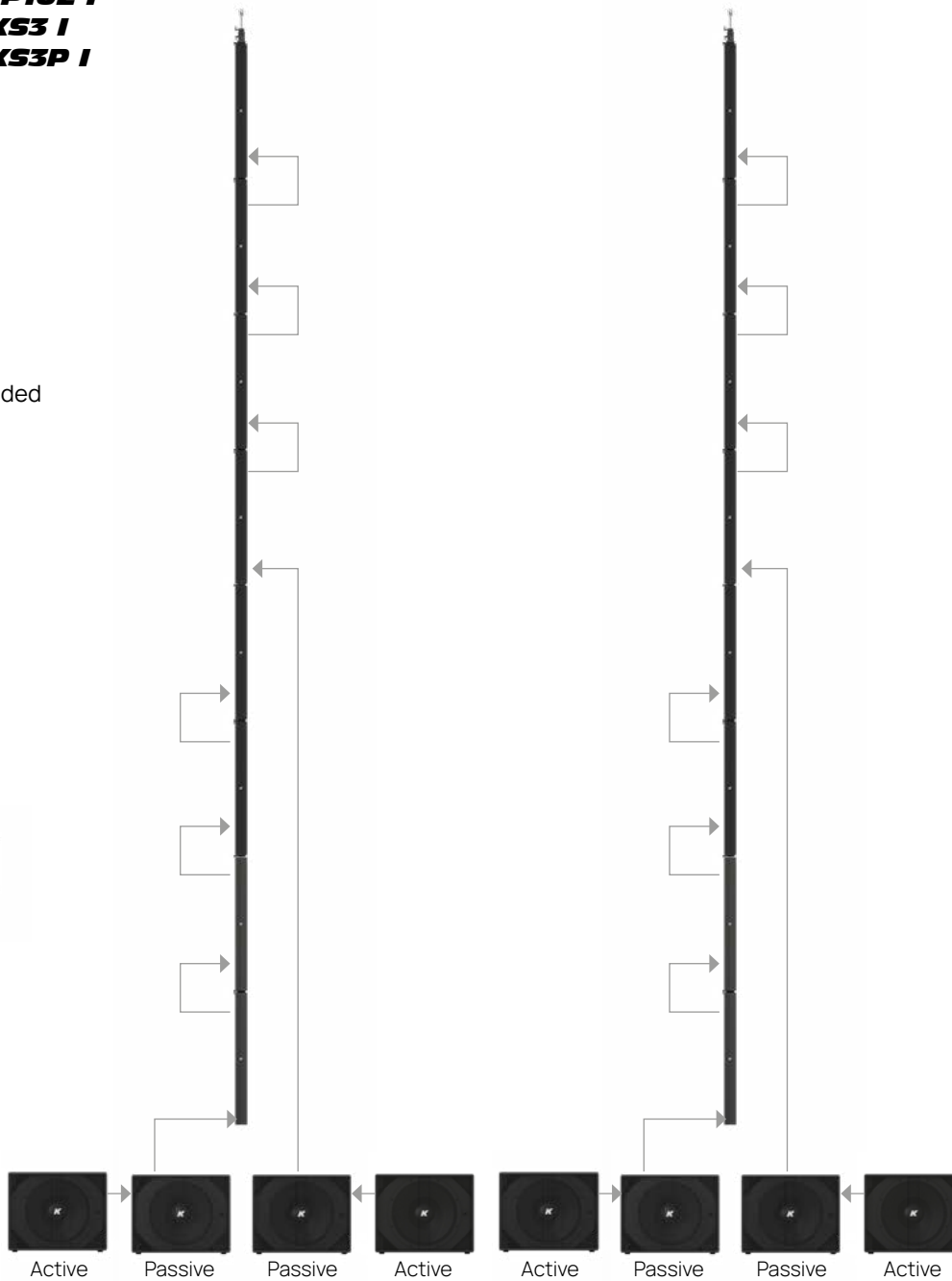

CONFIGURATION 1

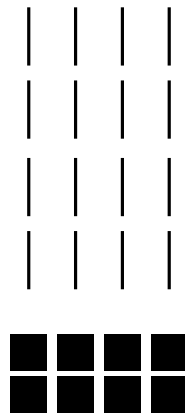

CONFIGURATION 2

Optional Accessories
K-WALL2
K-WALL2L

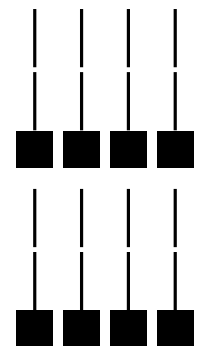

CONFIGURATION 3

Pinnacle mark II

Pinnacle-KR4

Pinnacle-KR802 II pag. 31

Pinnacle-KR804 II pag. 32



Kayman-KY102 I

8 x 4" neodymium
magnet woofers



Thunder-KS4

2 x 18" neodymium
magnet woofers

Pinnacle-KR4

Pinnacle-KR802 II

K-ARRAY
Unique Audio Solutions

- 4 x **Kayman-KY102**
- 1 x **Thunder-KS4 I**
- 1 x **Thunder-KS4P I**
- 4 x **K-JOINT3**
- 2 x **K-FOOT3**

Color Available

- White
- Black

Accessories Included



4 x **K-JOINT3**



2 x **K-FOOT3**

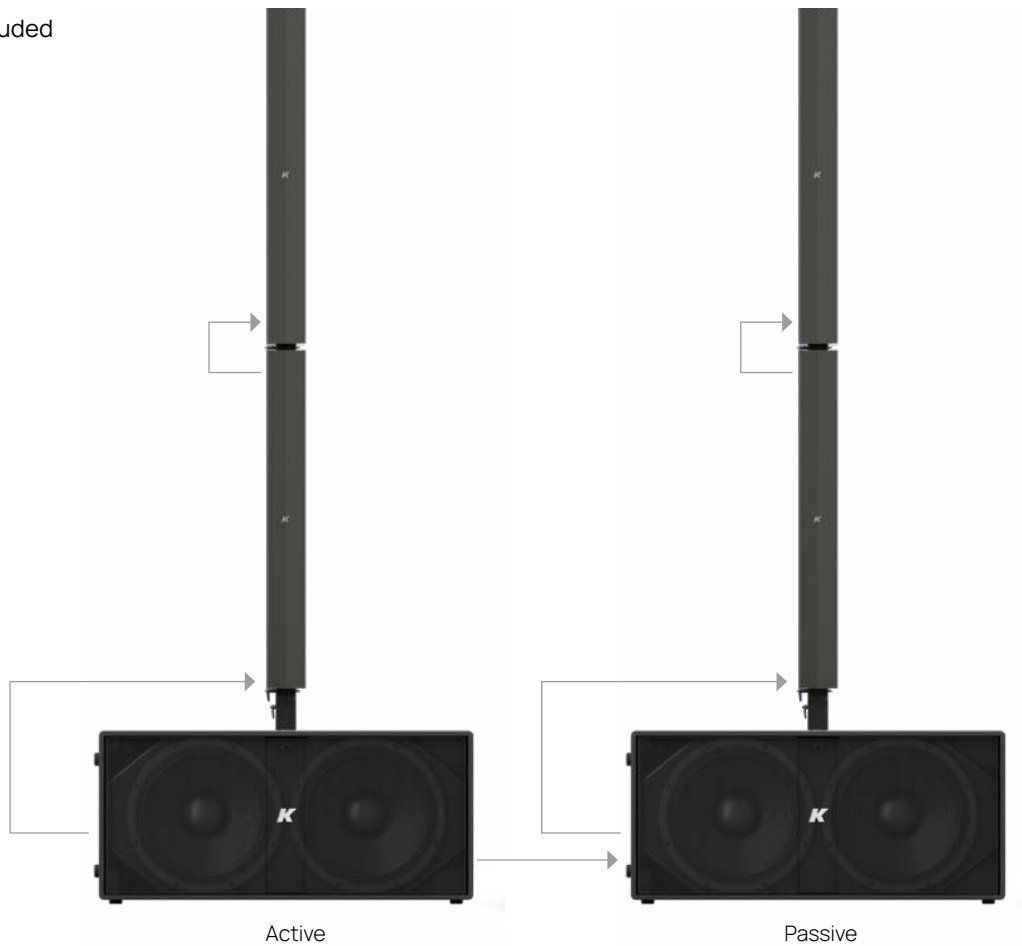

CONFIGURATION 1

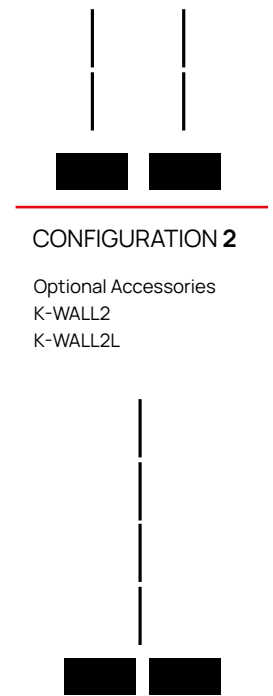

CONFIGURATION 2

Optional Accessories
K-WALL2
K-WALL2L

CONFIGURATION 3

Pinnacle-KR4

K-ARRAY
Unique Audio Solutions

Pinnacle-KR804 II

- 8 x **Kayman-KY102**
- 2 x **Thunder-KS4 I**
- 2 x **Thunder-KS4P I**
- 2 x **Flybar**
- 8 x **K-JOINT3**
- 4 x **K-FOOT3**

Color Available

- White
- Black

Accessories Included



8 x **K-JOINT3**



4 x **K-FOOT3**



2 x **FLYBAR**

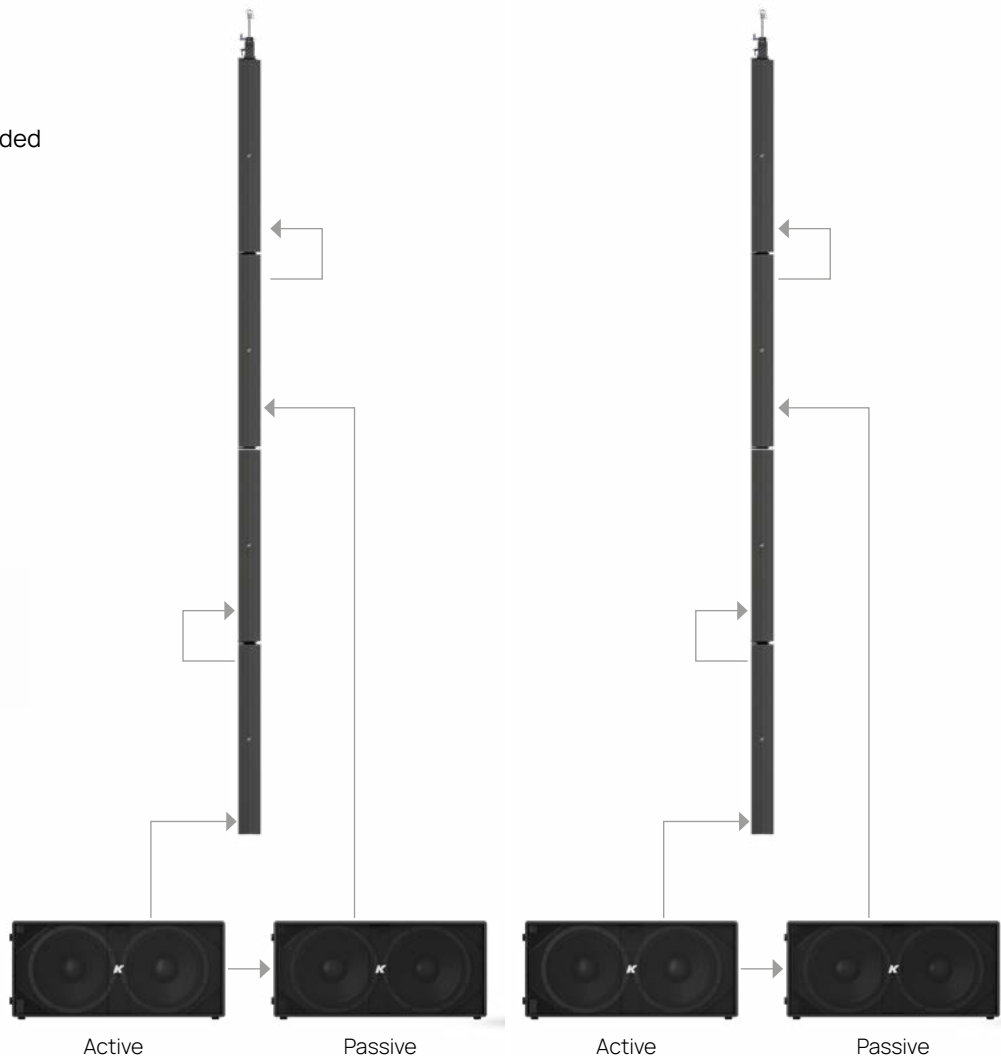

CONFIGURATION 1

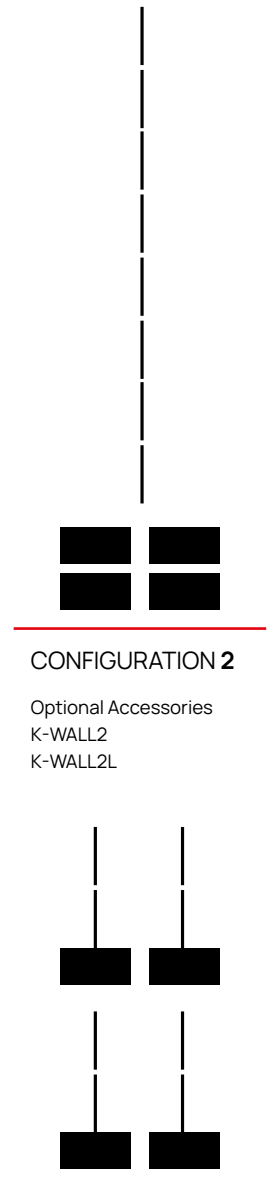

CONFIGURATION 2

Optional Accessories
K-WALL2
K-WALL2L

CONFIGURATION 3

Pinnacle-KR4

2 x **Pinnacle-KR804 II**

16 x **Kayman-KV102**

4 x **Thunder-KS4 I**

4 x **Thunder-KS4P I**

2 x **Flybar**

16 x **K-JOINT3**

4 x **K-FOOT3**

Color Available



Accessories Included



16 x **K-JOINT3**



4 x **K-FOOT3**



2 x **FLYBAR**

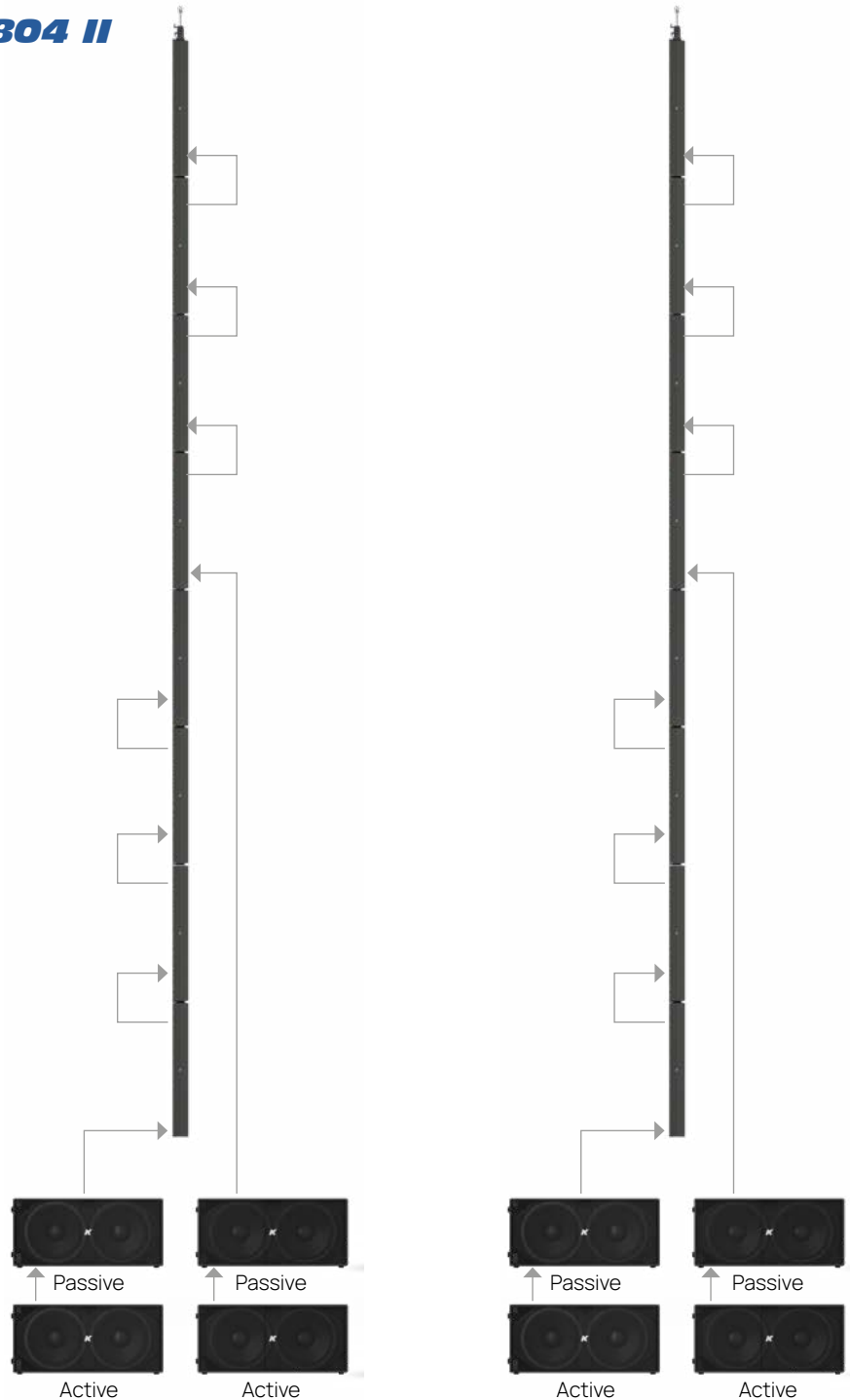

CONFIGURATION 1

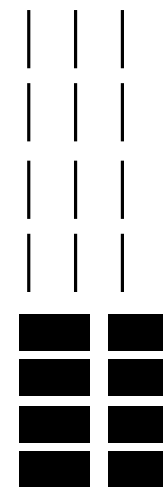

CONFIGURATION 2

Optional Accessories

K-WALL2

K-WALL2L

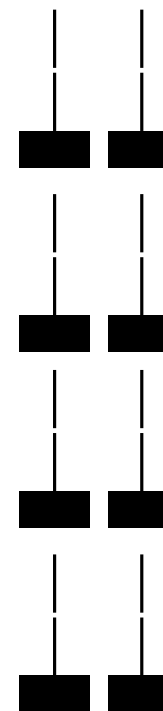

CONFIGURATION 3

K-ARRAY

Unique Audio Solutions

K-ARRAY s.u.r.l.
Via P. Romagnoli 17 | 50038 Scarperia e San Piero
Firenze | Italy

www.k-array.com